



Eagle Crusher *HAMMERMILL*

Eagle Crusher Hammermills are designed for maximum strength at a minimum weight and are ideal for use when budget and space are limited or when portable mounting is necessary.

Features

- ❶ Solid yoke hammers are stagger mounted to equalize crushing efficiency and reduce concentrated stress during shock loading.
- ❷ Replaceable, heavy-duty grate bars assure precise product sizing from 4-inch minus down to 100% minus 3/16-inch.
- ❸ Simple shim adjustment of impact curtain permits fast and precise changes in product size.
- ❹ Spherical, self aligning, double roller bearings are in split housing for easy replacement.
- ❺ Manganese steel breaker plates on impact curtain are fully reversible and interchangeable to maximize wear metal utilization.
- ❻ Long wearing AR side wear liners provide maximum housing protection and are bolt-mounted for easy maintenance.
- ❼ All models open completely for easy access during maintenance and wear part change out.

Additional Features

- Provides highly efficient internal screening capability via the adjustable heavy-duty grate bars.
- Maintains precise positioning and smooth performance of the bearing housing at all times with its recessed pillow-block mounting.
- Eliminates rotor shifting during operation via special steel locking nut and locking washer on rotor shaft.
- Reduces excessive stress during operation, assuring maximum wear life, via its specially designed heavy duty frame and rotor mounting system.
- Easily facilitates yoke hammer replacement, enabled by pivot pin mounting with common cotterpin locking.
- Permits replacement of individual sections of the shaft, as required, due to spider discs, keyed to the shaft, which also assures stationary positioning.
- Provides support and easy change out of the curtain support bar via split-mounted locking bar.

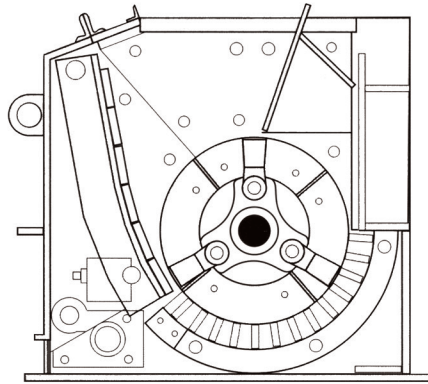

HAMMERMILL* Technical Specifications

Model	24 x 32	24 x 48
Feed Opening	20" x 32" / 508mm x 813mm	22" x 48" / 559mm x 1219mm
Diameter of Hammer Swing	24" / 610mm	24" / 610mm
Width Between Liners	32" / 813mm	48" / 1219mm
Main Frame Thickness	3/4" Steel / 19mm Steel	3/4" Steel / 19mm Steel
Diameter of Main Shaft (Center)	4" / 102mm	4" / 102mm
Diameter of Main Shaft (at Sheave)	3 3/8" / 86mm	3 3/8" / 86mm
Bearings (Self-Aligning, Spherical)	Double-Roller	Double-Roller
RPM	800-1600	800-1600
Hammers (Solid)	Manganese	Manganese
Number of Hammers	6	9
Diameter of Hammer Pins	1 1/4" / 32mm	1 1/4" / 32mm
Grate Bars (Screening, Standard Size)	1" x 3" x 33" / 25mm x 76mm x 838mm	1" x 3" x 49" / 25mm x 76mm x 1245mm
Spacers (Available)	3/16" to 2" / 5mm to 51mm	3/16" to 2" / 5mm to 51mm
Horsepower (Required for Limestone)	50 to 100HP / 37 to 74 kW	75 to 150HP / 55 to 110 kW
Overall Height	46" / 1168mm	46" / 1168mm
Overall Length	52" / 1321mm	52" / 1321mm
Overall Shaft Length	61" / 1549mm	80" / 2032mm
Weight (Approx.)	5600lbs / 2540kgs	6825lbs / 3095kgs
Overall Size	84.4 ft ³ / 7.84 m ³	110.7 ft ³ / 10.28 m ³

*Design specifications subject to change without notice.

A Wide Variety of Applications

- Asphalt
- Wash-out concrete
- Concrete block
- Brick
- Limestone
- Coal
- Graphite
- Slag
- Salt
- Gypsum
- Carbon
- Fertilizer Materials

Check with your Eagle Sales Representative for numerous, additional applications.